

DAIQUAN XIAO, Ph.D.¹

Email: xiaodaiquan@hust.edu.cn

ZHIHE WEN, Master Student¹

(Corresponding author)

Email: wenzhihe@hust.edu.cn

XUECAI XU, Ph.D.¹

Email: xuecai_xu@hust.edu.cn

ŽELJKO ŠARIĆ, Ph.D.²

Email: zsaric@fpz.hr

¹ Huazhong University of Science and Technology,

School of Civil Engineering and Mechanics

No.1037, Luoyu Road, Wuhan, China

² University of Zagreb,

Faculty of Transport and Traffic Sciences

Vukelićeva 4, 10000 Zagreb, Croatia

Traffic and Environment (Ecology)

Preliminary Communication

Submitted: June 8, 2015

Accepted: Feb. 17, 2016

SIMULATION AND ANALYSIS OF THE BUFFER FUNCTION OF FREEWAY GREENING ON OUT-OF-CONTROL VEHICLES

ABSTRACT

Freeway greening and traffic safety have been arousing more and more attention. The purpose of this study is to investigate the role of flexible green planting in buffering out-of-control vehicles. The stopping distances of vehicle rushing into greening were tested on eight groups of initial speeds range from 5 km/h to 40 km/h in green belt, and a simplified mathematical model was built to simulate the buffering process. The results indicated that the greening plants have certain buffering effect on vehicles and alleviate the crash damage within 30 m of the stopping distance for the vehicles under 40 km/h, while the simplified mathematical model could reflect the buffering process of the plants actually by simulating the speed attenuation process. It was found that the two types of resistance produced by the plants, i.e. counterforce of plant trunks and friction of branches and leaves are the major factors during the vehicle deceleration.

KEY WORDS

freeway greening; traffic safety; buffer planting; crash experiment;

1. INTRODUCTION

Statistical results show that about 30% of accidents on the freeway are caused by the vehicles rushing off the roads in China, among which the proportion of severe accidents is over 62%, and about one third of deaths are due to vehicle collisions with obstructions every year [1]. Buffer planting can reduce the possible damage of accidents. By planting flexible and strong hedges or low bushes in the entrance of freeway service area and diverging areas of interchange ramps, as well as accident-prone sections, they can absorb the kinetic energy of the out-of-control vehicles, so that the passengers and vehicles can avoid severe injury in the event of accidents. Compared to other methods

of buffering, the green plants have superior advantages, such as purifying the air, reducing the traffic noise, beautifying the landscape, improving the roadway environment, decreasing the construction costs, etc.

This paper aims to investigate the role of flexible green planting in buffering out-of-control vehicles at certain speeds. By considering the vehicles' chassis height, collision angle, planting density and other factors, the speed trend for out-of-control vehicles was determined according to the attenuation of green plants. Based on the results, the plant disposition form is determined from mechanics demand, and the conclusions can be used to reduce the injury severity, and provide one beneficial method for freeway greening on traffic safety.

2. LITERATURE REVIEW

Greening has different forms in urban city such as road planting, parks and open spaces, sky terraces, rooftop gardens, vertical greening on building walls and so on. The high-quality greening should be focused on many functional benefits. The important one is that greening is beneficial to health. Velarde [2] analyzed the range of landscapes used in environmental psychology studies, and the evidence of health effects was related to these landscapes. It was found that the natural landscapes gave a stronger health effect compared to urban landscapes. Lachowycz [3] developed a framework about the relationships between green space and health. Another functional benefit is that greening improves the ecological environment. Kattel [4] mentioned that urban green areas could help achieve effective urban ecosystem management and promote ecological resilience. Moreover, greening

also has some impact on the climate. Skelhorn [5] analyzed the impact of green space on air and surface temperatures through case study, and the results provided a framework for realistic greening interventions and outcomes in a temperate climate.

Freeway greening is an important part of the freeway system. Urban freeway greening cannot only beautify the environment, but it can also provide other functions such as anti-glare capability in median area, visual line guidance, accident protection, environmental ecologic protection, etc. Xiang [6] developed evaluation procedures and models for freeway landscape evaluation. The main evaluation indices considered are anti-glare capability in median area, soil stability enhancement capability in slope embankment area, and environmental ecologic protection capability in roadside area. In addition, landscape scenic view quality is another important factor. Zhan [7] appraised the roadsides greening and put forward the appraisal principles and methods of urban freeway greening with seven indicators. By considering beautifying the road and enriching the landscape as the goal, roadside greening also provides visual guidance. Van Renterghem [8] discussed the possibility of reducing the surface transport noise by natural means, e.g. greening.

Some studies have indicated that highway landscaping is closely related to traffic safety. Mok [9] compared the safety performance of parallel sections of freeways and parkways in terms of fatal accident rate and an accident cost measure, and proved that different greening parallel sections have different safety performances. In his later study, Mok [10] made a before-and-after comparison of crashes as a quantitative measure of roadside greening to test the effect of landscape improvements on driver performance. The findings of this study showed a significant decrease in crash rate after landscape improvements were implemented at the 95% confidence level on 10 urban arterial or highway sites in Texas. Wolf and Bratton [11] analyzed national traffic collision data to address concerns about urban trees and traffic safety, including crash incidence and severity. The findings acknowledged the serious consequences of tree crashes. Antonson [12] examined the effect of three Swedish landscape types on driving behaviour through a driving simulator study, and the results indicated that landscape also appears to be relevant to traffic safety.

The relationship between landscape installations and safety or pedestrian activity in clear zone was evaluated by Naderi [13] through case study. Preliminary findings indicated that the improved definition of spatial edge resulting from typical kerbside and median landscape treatment in the clear zone appears to solicit positive behavioural responses by either attracting pedestrian activity or improving driver safety. Furthermore, some scholars investigated safety functions of freeway greening including the buffer function.

Zhang [14] discussed the visual guidance, alignment foretold, nervousness dispelled, transition between brightness and dullness and buffer functions of planting, and analyzed some issues influencing safety in highway planting. Xiao [15] established three functional objectives of different greening regions on highway, which includes traffic safety, landscape aesthetics and ecological restoration, and incorporates the buffer planting in the objective of traffic safety.

3. METHODOLOGY

3.1 Buffer experiment

3.1.1 Experiment design

Similar to the guardrail collisions study, the speed attenuation was simulated under real traffic conditions after the actual vehicles rushed into the shrubs area. The scheme is as follows: Firstly all the apparatus required by the experiment was set up on the site. Then the typical vehicles driven by the same driver were accelerated to the specified speed within a certain distance, and rushed into the bush area at a constant angle under the free state while no brake measures were taken. Eventually, the whole dynamic variation process of the vehicle was recorded from sliding till stopping by measuring apparatus and photographic equipment.

Vehicle selection: With the increasing of private car ownership, its proportion has been raised on freeways. According to the results of on-site accidents investigation, when the collision speed is no less than 100km/h, the overturning would not occur; on the other hand, the trucks with high gravity and heavy weight tend to overturn after crashing into a semi-rigid beam guardrail, and the plants cannot provide the buffer function. Therefore, passenger cars were considered as a typical study subject for the experiment. In this study, the standard vehicle selected is Buick Excelle 2013 1.5L Auto Classic, General Motors Corporation and the main parameters of the vehicle are shown in Table 1. There were one driver and one passenger in the car during the experiment with the weight of 65 kg per person.

Table 1 – Vehicle parameters for the experiment

Index	Unit	Value
Car Length	m	4.515
Car Width	m	1.725
Wheelbase	m	2.6
Front Track	m	1.475
Rear Track	m	1.475
Chassis Height	m	0.23
Empty Quality	kg	1,230

Experiment site: Road greening usually includes three types - trees, shrubs and herbs. The rigidity of the trees is intense and the impact force is strong after the out-of-control vehicles rush into them, which causes severe body injury, whereas the herbs are too low and only have friction force to wheels, covering the small function area and causing the buffer effect not to be obvious. Thus the shrubs are selected to stop the out-of-control vehicles because of its flexible texture and strong impact resistance. Therefore, one shrub greening area was selected as the experiment site. The type of the plants selected in the area is *Photinia* with the average height of 0.8 m, and planting density 26/m², i.e. plant spacing about 0.2 m. Due to limited conditions, the experiments were conducted in a wide green belt, and the flat space next to the green belt was considered as the acceleration area.



Figure 1 - Experiment site - *Photinia* green belt

3.1.2 Experiment process and data collection

Since the experiment of rushing into the shrubs is dangerous, and it is hard to control various experiment conditions, in this study the collision speed did not exceed 40 km/h, since the out-of-control vehicles do not rush into the shrubs until the collision of the guardrail absorbs part of the kinetic energy. The speed value was changed from 5 km/h to 40 km/h per 5 km/h, and three experiments were performed at each initial speed value. Generally speaking, the conflicts between vehicles and roadside barriers are side collisions, and in order to better reflect the real conditions, the angle of the vehicles rushing into the green buffer area was set as 30 degrees in our experiment.

Experiment procedure is as follows:

- 1) Measure the basic data of parameter indices for the shrubs with the tape, including the average height and crown radius, and then select multiple 1 m² greening land to count the number of shrubs per square meter so that the average planting density can be obtained.
- 2) Set the camera and other equipment at appropriate locations and arrange the experiment perform-

- ers of the vehicles inside and outside, and draw a guide line with chalk on the ground.
- 3) The experimental vehicles driven by experienced drivers were accelerated to specified speeds, and rushed into the greening area along pre-drawn guide line at an angle of 30 degree.
- 4) When the vehicle rushed into the greening area, no brake measures were taken and the car was left sliding till the zero speed. The experiment performers inside the vehicle recorded the whole dynamic variation process of the vehicle panel with a camera while the performers outside recorded the whole process of free deceleration within the shrubs area.
- 5) Measure the stopping distance with tape from entering into the shrub area, and only select the displacement of the left-front wheel as the sliding distance.

Repeat the steps above three times at the same initial speed. The following measurement indices can be obtained, such as the initial speed, stopping distance, plants characteristics (including plant height, planting density and species) and vehicle characteristics (including the length, width, height of chassis and vehicle weight).

3.2 Model establishment

Based on experimental observation within real vehicles and environmental conditions, the simplified assumptions were presented and a simplified model was established. The main point of the model focused on the stopping distance and speed attenuation process within the shrub area. By neglecting the rigid rotation and deformation of the vehicles, the movement process can be simplified as plane motion of mass point. Through simulation the resistance of the vehicle at each moment can be calculated; consequently, the stopping distance and speed attenuation process of the out-of-control vehicles can be achieved. In accordance with the results, the types and forms of greening plants can be arranged appropriately, which eventually will alleviate the consequence of crashes and improve the travelling safety.

3.2.1 Resistance analysis

When the vehicle rushes into the green area, the buffering process is mainly affected by two parts of resistance, i.e. the general driving resistance and plants buffer resistance.

The general driving resistance includes air resistance, tyre rolling resistance and transmission resistance [16, 17].

Air resistance F_w : Air resistance comes from air pressure and viscous friction. Wind tunnel test and related studies consider that air resistance is proportional to the square of the speed. When the vehicles

run under windless conditions, air resistance can be expressed as formula:

$$F_w = \frac{C_d A v^2}{21.15} \quad (1)$$

where C_d is the air resistance coefficient which is related to the shape of the vehicle, vehicle ventilation, air friction and so on; A is an automotive windward area [m^2]; and v is the vehicle speed [m/s].

Tyre rolling resistance F_f : Tyre rolling resistance is usually expressed as a product of rolling resistance coefficient f and wheel load, while f is usually described as a quadratic polynomial of speed. Without slope, the tyre rolling resistance is represented as formula:

$$F_f = (a_0 + a_1 v + a_2 v^2) \cdot mg \quad (2)$$

where a_0, a_1, a_2 are the rolling resistance coefficients, and v is the vehicle speed [m/s].

Transmission resistance F_c : During the sliding process of real vehicles, transmission resistance is related to oil viscosity, transmission gear accuracy and grinding situation, the wheel bearing adjustment, lubrication status and so on. This paper considers the transmission resistance as formula:

$$F_c = b_0 + b_1 v \quad (3)$$

where b_0, b_1 are the transmission resistance coefficients, and v is the vehicle speed [m/s].

Since there are very limited studies about plants resistance, according to the experimental observation, in this study the plants resistance to vehicles mainly includes counterforce produced by bending deformation of plant trunks from the front of the vehicle, and the friction between branches and chassis from the bottom of the vehicle.

Counterforce of trunk bending deformation F_t : By simulating the plant trunk as flexible pole with fixed root, and referring to the method computing the deformation of great flexibility for slender long overhanging beam under concentrated load, the counterforce of the trunk under certain deformation conditions can be solved with numerical integration [18]. Counterforce of trunk bending deformation F_t is the horizontal component of the bending reaction force.

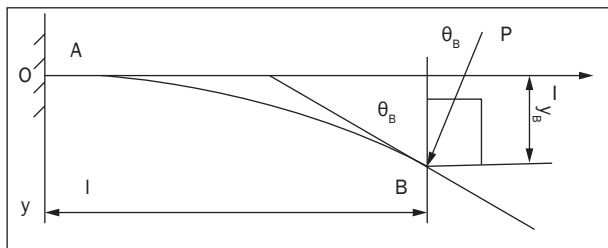

Figure 2 – Trunk bending force

$$F_t = P \cdot \cos(\theta_B) = \frac{El}{l^2} \cdot \frac{1}{2} \left(\int_0^{\theta_B} \frac{\cos \theta}{\sqrt{\sin(\theta_B - \theta)}} d\theta \right)^2 \cdot \cos(\theta_B) \quad (4)$$

where θ_B is the rotational angle of the contact point B [rad], El is the flexural rigidity [$Mpa \cdot m^4$], and l is the force point height, i.e. the chassis height [m].

Friction of branches and leaves F_b : Apart from the friction between branches and vehicles, there exists the friction of branches and leaves with each other. Although the friction is similar to fluid to a certain degree, branches and leaves are not typical fluid because they lack the viscosity of a fluid. So, in this paper the fluid resistance formula and experimental observations combined consider that branches friction is proportional to k -th power of speed and the contact area [19].

$$F_b = c \cdot v^k \cdot S_c \quad (5)$$

where c is the resistance coefficient, and S_c is the contact area, i.e. the vehicle chassis area (ignore the vehicle side surface) [m^2].

In summary, the total resistance during the buffering process of the vehicles to the shrub area is:

$$F = F_w + F_f + F_c + F_t + F_b \quad (6)$$

3.2.2 Mathematical model

In order to facilitate the description of the relative position between plants and the vehicle, in this model it is assumed that plants were planted evenly. In the Cartesian coordinate system shown in Figure 3, the plant interval is considered as one unit, and the coordination of the first plant hit by out-of-control vehicle is defined as the origin; so the relative position of each plant and vehicle can be calculated and then the deformation of plants and the vehicle resistance can be obtained.

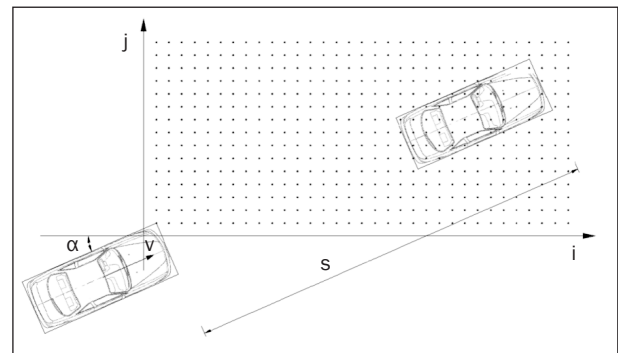

Figure 3 – Simplified model plan view

In the simplified mode, when the vehicle rushes into the shrub area at a certain speed v and angle α , it starts to decelerate due to the resistance from the first colliding plant, and stops after the distance sliding along the original travelling direction. It is assumed that the entire system is considered to be in a static, i.e. quasi-static state at each moment. When given a small time increment (set to be 0.01 s in the model),

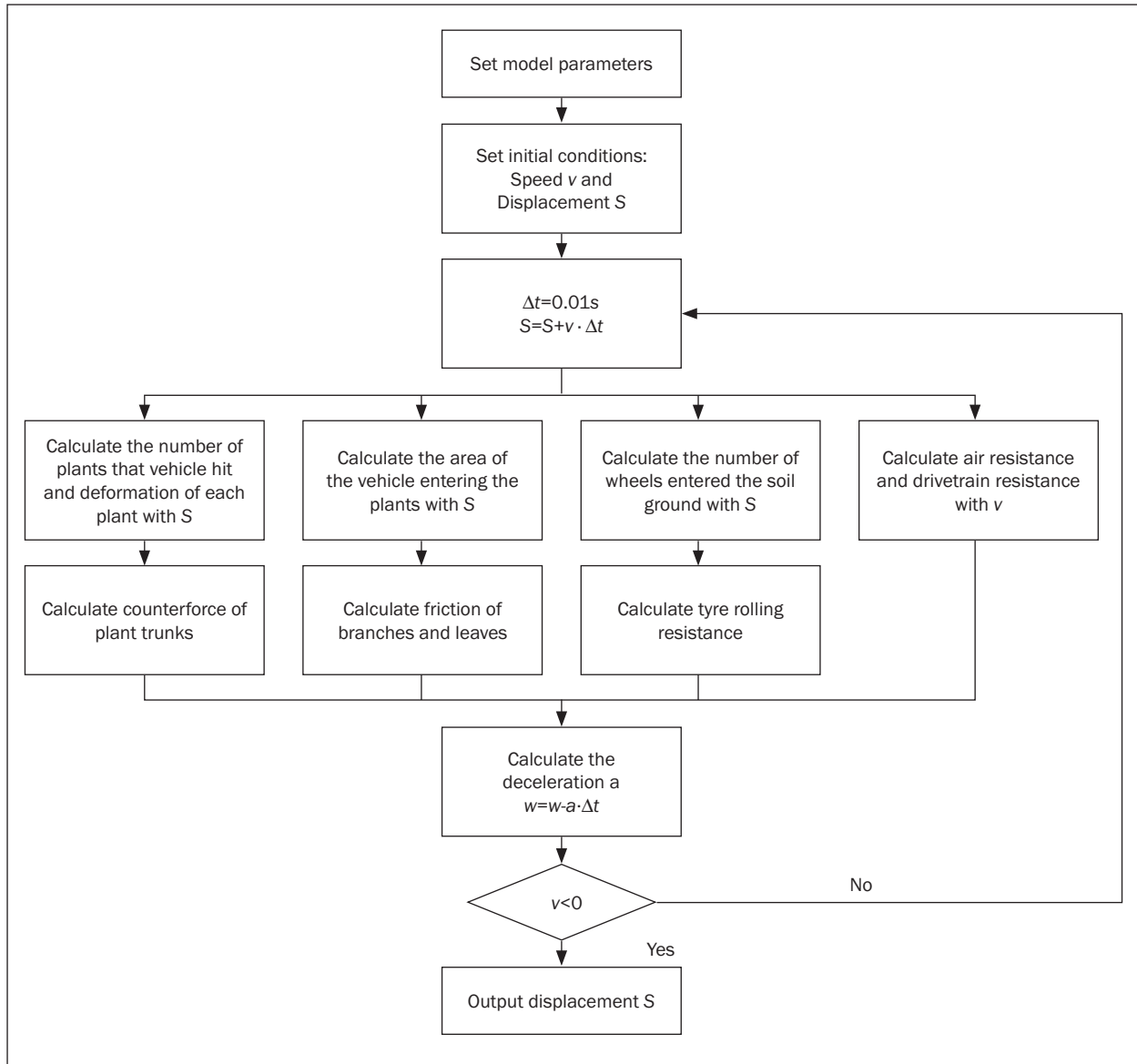

Figure 4 – Simplified model calculation steps

the system reaches the static equilibrium under this state. The vehicle speed is set as v^n and the travelling distance is S^n at a certain moment t^n .

Then at moment t^{n+1} , the vehicle speed is v^{n+1} :

$$t^{n+1} = t^n + \Delta t \quad (7)$$

Meanwhile, the vehicle displacement is:

$$S^{n+1} = S^n + \Delta S = S^n + v^n \Delta t \quad (8)$$

Because each moment is considered as static, the resistance within the time interval from t^n to t^{n+1} can be regarded as constant. According to Newton's laws of motion:

$$ma^{n+1} = F^{n+1} \quad (9)$$

$$v^{n+1} = v^n + a^{n+1} \Delta t \quad (10)$$

where v^{n+1} is the vehicle speed at moment t^{n+1} , v^n is the vehicle speed at moment t^n , F^{n+1} is the total resistance to vehicle at moment t^{n+1} , a^{n+1} is the deceleration at moment t^{n+1} , Δt is a small time increment.

With incremental algorithm, it is possible to calculate the deformation of the plants and the corresponding vehicle displacement at each moment, and then the movement of the vehicle during the entire buffer time can be achieved. The flow chart of the simplified model is shown in Figure 4.

4. RESULTS

4.1 Experimental results

Through the observation experiment, the whole deceleration process of the vehicle within plants area can be described as:

Firstly the front section of the vehicle rushes into the shrub area and the bumper hit the bush plants. As the vehicle continues to move forward, the bush plants bend and fall, and then the bend plants slide into the bottom of the chassis. After the rear of the vehicle leaves the plants, the plants restore upright because of strong flexibility. Each plant repeats the same process, contact-bending recovery, while the vehicle decelerates gradually during the process. After one experiment was done, only part of the bush plants was fractured due to wheel rolling and the rest experienced no damage and neither did the occupants inside the vehicle.

There were eight groups of experiments performed, and each group corresponded to one initial speed with three times of collisions, and the buffer distance of vehicles rushing into the greening area at 30° angle is shown in Table 2:

Table 2 – Experimental data

Group	Initial speed (km/h)	Buffer distance(m)	Average Buffer distance(m)
1	5	4.9	4.5
		4.2	
		4.4	
2	10	6.1	6.6
		7.2	
		6.6	
3	15	8.5	9.2
		9.5	
		9.6	
4	20	13.5	14.0
		15.5	
		12.9	
5	25	17.0	17.8
		18.4	
		18.0	
6	30	23.2	22.3
		21.7	
		22.1	
7	35	23.1	24.6
		24.7	
		25.9	
8	40	29.5	28.6
		28.8	
		27.6	

Table 3 – Model calculation data

Initial speed(km/h)	5	10	15	20	25	30	35	40
Deceleration distance(m)	3.78	7.20	10.42	13.72	17.11	20.54	24.03	27.53

4.2 Model simulation

Known from the modelling and analysis process, there are many parameters during the establishment of the simplified model. The following parameters can be collected directly from the vehicle parameter manual, such as vehicle chassis height, vehicle quality, vehicle length, vehicle width, wheelbase, track width and other geometry parameters. Moreover, the plant spacing is 0.2 m and the average diameter is 1.5 cm from the field measurement. Besides, through mechanical tests the anti-bending rigidity of the plants is $EI=0.5 \cdot 10^3 \text{MPa} \cdot 2.5 \times 10^{-9} \text{m}^4$. Air resistance coefficient and the wheel rolling friction coefficient can be found in the relevant literature. According to rolling tests, the friction coefficient on soil is three times greater than of the normal pavement. The friction of branches and leaves is estimated by the experimental data, set $c=60$ and $k=1$.

By employing the simplified model and programming with Matlab software with initial speeds of the vehicles, the deceleration distances of the vehicle from different initial speeds to zero can be computed as in Table 3.

Set the initial speed of 20 km/h as an example, the curve of various resistances varying with displacement in the buffer process is displayed in Figure 5.

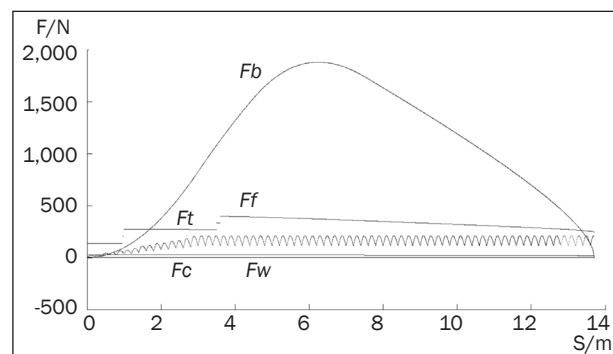

Figure 5 – Resistances change with displacement (20 km/h)

Seen from Figure 5, during the whole buffer process, air resistance F_w and transmission resistance F_c are very small, and the tyre rolling resistance F_f shows a sudden variation because of the different friction coefficients between the dirt and road. Counterforce of plant trunks F_t is associated with the travelling distance due to the impact of deformation, and gives a fluctuating change. Friction of branches and leaves F_b increases with the growth of the area when the vehicle enters into the bush area, and decreases rapidly with

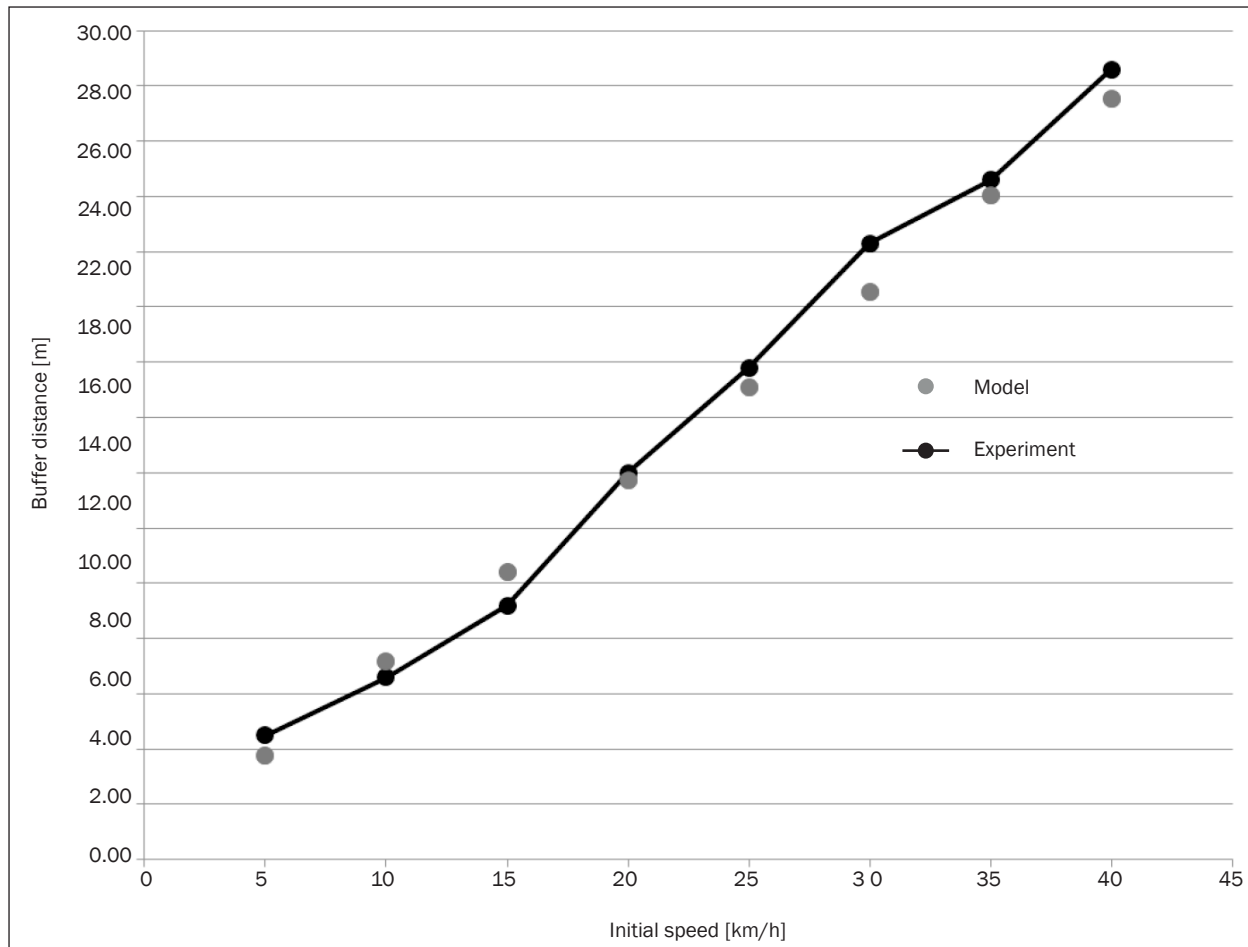

Figure 6 – Results comparison

the speed deceleration after the vehicle is fully into the shrub area.

The experimental results and the model calculation results were compared to verify the reasonableness of the model.

As shown in Figure 6, because there exists great randomness in the buffer process within the greening area, the model results are larger at lower speeds and smaller at higher speeds compared to the experimental results. The results are such that the buffer function may be weakened due to the repeatedly rolling of the same plant area from lower to higher speeds. However, the model results are consistent with those of experimental data in trend, and the computation can reasonably reflect the actual situation, which is valuable for directing actual greening work.

5. DISCUSSION

Although the plants can shorten the sliding distance by about 70%~90% compared to road sliding [20], the sliding distance is still too long for freeway greening. However, by changing the model parameters such as plant density and the diameter of plants, it may be possible to shorten the stopping distance to

under 20 m at the speed of 40 km/h. With the help of the slope, the width of buffer planting can be even shorter. From the simulation of the buffer process, some suggestions can be made.

Shown from the resistance variation of the simulated buffering process, the friction of branches and leaves are the main reason to decelerate the vehicle in the earlier stage, which accounts for more than 80% of the total resistance. With the decreasing of speeds, the effect of counterforce of plant trunks and tyre rolling resistance are gradually increased, and reach around 50% of the total resistance later. It can be seen that in order to improve the buffering effect of greening plants on vehicles, amidst lush bush should be planted in the front area of 20 m to increase the friction of branches and leaves to the chassis, and sturdy bushes should be appropriately planted in the back area of 10 m. Generally speaking, the higher the plant height, the larger the diameter and the stronger the anti-bending rigidity of trunks. Meanwhile, the plants planted should be at least higher than the height of the chassis, but the plants with 0.5 m or more in diameter would cause fatal accidents [21], so the plants should be under 0.5 m in diameter. Moreover, the plants should have good flexibility so that they can bear repeated attacks. At the

same time, in terms of guaranteeing the survival rate of plants, the planting density should be appropriately increased, which is not only helpful to improve the density of branches and leaves, but also beneficial to increase the number of plants providing resistance.

6. CONCLUSIONS

By experiment and modelling, this study investigates the speed attenuation process and the buffering effect of greening plants on the vehicles after the out-of-control vehicles rush into the shrub area which provides theoretical support for realizing the appropriate planting of greenings and securing the out-of-control vehicles in the future. During the experimental process, the relationship between the initial speed and the stopping distance was mainly analyzed, while various influencing factors, such as air resistance, tyre rolling friction, transmission friction, deformation resistance of the plant trunks and friction of branches and leaves, were considered comprehensively in modelling. The following conclusions can be reached:

- 1) In the buffer experiment, the buffer distance increases with the increasing of the initial speed. It indicates that the greening plants have certain buffering effect on vehicles and alleviate the crash damage within 30 m of stopping distance for the vehicles under 40 km/h.
- 2) By establishing the simplified model to simulate the speed attenuation process, and comparing with the experimental results, the errors are acceptable within reasonable range, implying that the simplified model could actually reflect the buffering process of the plants.
- 3) From the analysis of the simplified model, it can be found that the two types of resistance produced by the plants, i.e. counterforce of plants trunks and friction of branches and leaves are the major factors during the vehicle deceleration, while tyre rolling resistance is also a significant factor. Air resistance and transmission resistance are very small by comparison. The higher the speeds, the greater resistance the vehicles receive.
- 4) From the simplified model, the relationship among the stopping distance, resistance and the initial speed can be obtained. By analyzing the resistance variation, it is recommended that the layout of the buffering area be arranged with luxuriant bushes of 20 m and sturdy bushes of 10 m, and the planting density be increased reasonably.

This paper has made some progress in analyzing the buffer function of freeway greening, but in order to deeply understand the buffering process and apply this to the freeway greening, there are still many aspects to be improved.

During the modelling process, in order to analyze simply the force and deformation of each plant, it was

assumed that each plant is an independent homogeneous pole, whereas the actual plant is generally thin on top and thick at the root, and the anti-bending rigidity is not even. Additionally, since the vehicle chassis is not a plane, the acting force is very complicated for the branches and leaves, and further study is required to conduct the resistance relationship between the vehicles and different density conditions of branches and leaves, so more accurate computation method can be presented. Besides, some random factors, such as the variation of air resistance, the blockage of plant roots to the tyres, partial fracture of plants, etc., were neglected. Due to the limitation of the experimental conditions, it is not possible to compare the influence of the different plant forms or different plant densities on the buffering function, and other factors, such as high-speed vehicles (over 40 km/h), types of vehicles, were not considered in this study. It is still unknown whether buffer planting is cost-effective or how much loss it would reduce. Therefore, more studies should be performed to investigate the reasonable plant forms to guide the greening planting in the future.

ACKNOWLEDGMENT

This work was supported by the Natural Science Foundation of China (No.51308242).

肖代全, 博士

Email: xiaodaiquan@hust.edu.cn

华中科技大学

土木工程与力学学院

珞瑜路103号, 武汉, 中国

温智和, 硕士

Email: wenzhihe@hust.edu.cn

华中科技大学

土木工程与力学学院

珞瑜路103号, 武汉, 中国

徐学才, 博士

Email: xuecai_xu@hust.edu.cn

华中科技大学

土木工程与力学学院

珞瑜路103号, 武汉, 中国

Željko Šarić, 博士

Email: zsaric@fpz.hr

萨格勒布大学

交通运输科学学院

Vukeliceva 4, 10000 萨格勒布, 克罗地亚

高速公路绿化对失控车辆的缓冲作用的模拟与分析

摘要

高速公路绿化和交通安全问题引起了越来越多的关注。本文旨在探究柔性绿色种植在缓冲失控车辆时的作用。本研究在速度为5km/h至40km/h范围内测试了8组不同初始速度条件下车辆冲入绿化植物

时的停止距离，并建立了简化数学模型来模拟车辆的缓冲过程。实验结果显示速度在40km/h以下车辆的停止距离不超过30m，表明绿化植物对车辆具有一定的缓冲作用并减轻冲撞损伤。通过模拟速度的衰减过程，简化数学模型能有效反映植物的缓冲过程，显示出植物产生的两种阻力——植株弯曲反作用力及枝叶摩擦力是车辆减速过程中的主要因素。

关键词

高速公路绿化，行车安全，缓冲栽植，冲撞实验

REFERENCES

- [1] Lei ZB. Research on the New Mechanism of Collision Protection for Semi-Rigid Fences. *Journal of Vibration and Shock*. 2002 Mar;21(1):1-6.
- [2] Velarde MD, Fry G, Tveit M. Health effects of viewing landscapes – Landscape types in environmental psychology. *Urban Forestry & Urban Greening*. 2007;6(4):199-212.
- [3] Lachowycz K, Jones AP. Towards a better understanding of the relationship between greenspace and health: development of a theoretical framework. *Landscape and Urban Planning*. 2013 Nov;118:62-69.
- [4] Kattel GR, Elkadi H, Meikle H. Developing a complementary framework for urban ecology. *Urban Forestry & Urban Greening*. 2013;12(4):498-508.
- [5] Skelhorn C, Lindley S, Levermore G. The impact of vegetation types on air and surface temperatures in a temperate city: A fine scale assessment in Manchester, UK. *Landscape and Urban Planning*. 2014 Nov;121:129-140.
- [6] Xiang QJ, Yuan L, Lu J. Evaluation Approaches of Freeway Green Landscape. *The First International Conference on Transportation Engineering*; 2007 July 22-24; Chengdu, China.
- [7] Zhang H, Li C, et al. Evaluation Approaches of Urban Freeway Greening. *Applied Mechanics and Materials*. 2013 Aug;361:547-551.
- [8] Van Renterghem T, Forssén J, et al.: Using natural means to reduce surface transport noise during propagation outdoors. *Applied Acoustics*. 2015 Jan; 92:86-101.
- [9] Mok JH, Landphair HC. *Parkways or Freeways: Safety Performance Linked to Corridor Landscape Types*. Proceedings of Transportation Research Board 82nd Annual Meeting; 2002 Jan 12-16; Washington DC, USA.
- [10] Mok JH, Landphair HC, Naderi JR. Landscape improvement impacts on roadside safety in Texas. *Landscape and Urban Planning*. 2006;78(3):263-274.
- [11] Wolf KL, Bratton N. Urban trees and traffic safety: Considering US roadside policy and crash data. *Arboriculture & Urban Forestry*. 2006 July;32(4):170-179.
- [12] Antonson H, Mårdh S, et al. Effect of surrounding landscape on driving behaviour: A driving simulator study. *Journal of Environmental Psychology*. 2009 Apr;29(4):493-502.
- [13] Naderi JR. Landscape design in clear zone: effect of landscape variables on pedestrian health and driver safety. *Transportation Research Record: Journal of the Transportation Research Board*. 2003;1851(1): 119-130.
- [14] Zhang Q, Chen YR. Analysis of Relations Between Planting and Safety of High-Type Highways . *Highway*. 2005 Nov;11:197-202.
- [15] Xiao DQ. Study on Optimization of Highway Greening Engineering Based on Three Objectives [PhD thesis]. Chang'an University, 2011.
- [16] Gao YS. Analysis on Automobile Coasting Resistance. *Automobile Technology*. 2008;4(7):27-30.
- [17] Han ZQ. Measuring Automotive Air Resistance Coefficient by Coasting Test Method. *Automobile Technology* 2001;5(7):24-27.
- [18] Ge RH. A Way to Calculate the Deformation of Great Flexibility of Slender Long Overhanging Beam under Concentrated Load. *Chinese Journal Of Applied Mechanics*. 1997 Dec;14(4):71-77.
- [19] Li YB. Discussion on the method of inland ship sailing resistance calculation. *Journal of Waterway & Harbor*. 2002 Mar;23(1):7-11.
- [20] Chen Y. Research and Test on Transmission Resistance of Subcompact Vehicles based on Chassis dynamometer [PhD thesis]. Wuhan University of Technology, 2012.
- [21] Zeigler AJ. *Guide to management of roadside trees*. Michigan Department of Transportation. 1986.