

MIA JURJEVIĆ, Ph.D. Candidate
(Corresponding author)
E-mail: miajurjevic@gmail.com
Vozišće 12a, 51216 Viškovo, Croatia

SVJETLANA HESS, Ph.D.
E-mail: shess@pfri.hr
University of Rijeka, Faculty of Maritime Studies
Studentska 2, 51000 Rijeka, Croatia

Science in Traffic and Transport
Original Scientific Paper
Submitted: Apr. 13, 2015
Accepted: Feb. 2, 2016

THE OPERATIONAL PLANNING MODEL OF TRANSHIPMENT PROCESSES IN THE PORT

ABSTRACT

Modelling of a traffic system refers to the efficiency of operations for establishing successful business performance by examining the possibilities for its improvement. The main purpose of each container terminal is to ensure continuity and dynamics of the flow of containers. The objective of this paper is to present a method for determining the amount of certain types of containers that can be transhipped at each berth, with the proper cargo handling, taking into account minimum total costs of transshipment. The mathematical model of planning the transshipment and transportation of containers at the terminal is presented. The optimal solution, obtained with the method of linear programming, represents a plan for container deployment that will ensure effective ongoing process of transshipment, providing the lowest transshipment costs. The proposed model, tested in the port of Rijeka, should be the basis for making adequate business decisions in the operational planning of the container terminal.

KEY WORDS

operational planning; transshipment processes; optimal plan of container transshipment;

1. INTRODUCTION

An increased competition between seaports, especially between geographically close ones is a result of development of the container traffic, that imposes the necessity of better quality process for handling and storage of containers and impeccable organization of tasks at container terminals. The container terminal is a dynamic, open system with stochastic and unpredictable external factors. For this reason, systematic approach is required in the process of planning. The terminal should elaborate a plan for the process of container transshipment. The oscillations of transshipment of goods in ports are conditioned by unequal arrival of container ships and uneven duration of operations with containers. Due to unevenness of container traffic, the efficient planning for transshipment of container operations is recommended for shorter periods of time, not for longer terms (e.g. a year). This type of planning is considered as operational planning that

comprises the plan of taking over operations, layout of human resources and means necessary to perform these chores.

The problem is defined by two types of cargo loaded on two different berths of the container terminal. Three different modes of cargo handling have been applied.

The basic objective of this paper is to show the efficient way of organizing the transshipment process. In other words, to determine the quantity of certain type of cargo being transhipped at each berth and in the appropriate way. This will be conducted in the observed period of time, providing the lowest possible transshipment costs. The need for optimization using methods of operations research in container terminal operation has become more and more important. In order to accomplish this objective, a mathematical model is presented, so called multi-index transportation problem. The mentioned problem has been solved by applying the method of linear programming.

The optimal solution represents a plan for container deployment that will ensure effective ongoing process of transshipment at a port, taking into consideration the lowest possible costs. Based on the mentioned plan, it is possible to determine which means of transport is capacitated or has insufficient capacity. In operational planning, the application of the chosen model enables achieving the maximum of the mutual compatibility of adequate utilization of berths, port mechanization and employees of the terminal [1, 2].

One of the most important tasks for the successful operation of the container terminal is the selection of an appropriate process of transshipment and the type of transshipment means. The results here obtained can be a good base for decision-making in order to determine the optimal capacity of the necessary transshipment means. The model was tested at the port of Rijeka, taking into account the existing resources, available transshipment means and workers who participate in the process of transshipment.

There are many research papers in the observed field, primarily noted a survey of methods for

optimization of the main logistics processes and operations in container terminals [3]. The problem of managing a container exchange facility with multiple RMG is solved proposing an integer programming-based heuristic method [4]. Genetic algorithm (GA) techniques, used to reduce container handling/transfer time and ship's time at the port by speeding up handling operations, are applied for optimising the container transfer schedule at multimodal terminals [5]. An optimization methodology for container handling using genetic algorithm is also implemented in [6]. The Petri net model and the genetic algorithm have been chosen for solving the problem of berth and crane assignments [7]. The implementation of the queuing theory [8] could set an optimal capacity of the port container terminal, or a combination of the number of berths and cranes per berth with the minimum costs for the given traffic. With the objective of minimizing the total container handling time in a yard, encoding method for solving search space problems and a beam search algorithm are suggested in [9]. An integrated framework for various operation plans in container terminals is presented in [10] while the container terminal operation: current trends and future challenges are given in [11].

2. TRANSHIPMENT PROCESSES IN THE PORT

Ports are essentially providers of service activities, in particular for vessels, cargo and inland transport. As such, it is possible that a port may simultaneously provide high-quality service to vessel operators on the one hand and unsatisfactory service to cargo or inland transport operators on the other. Therefore, port performance cannot normally be assessed on the basis of a single value or measure [12]. The management of a container terminal is a complex process that involves many decisions. Among the problems to be solved, there are the spatial allocation of containers on the terminal yard, allocation of ships to berths and cranes, scheduling priorities and operations in order to maximize performances based on some economic indicators [7].

Traffic oscillations in ports, which cannot be avoided or foreseen in terms of quantity, both in present time and future, influence the issue of dimensioning all elements involved in a port service process [13]. Intelligent terminal layouts can increase the terminal capacity, reduce the time for container transport and thus, reduce the turnaround time of ships enormously [4]. The container terminal represents a complex system with highly dynamic interactions between the various handling, transportation and storage units and incomplete knowledge about future events [14].

To reach the optimal functioning of the terminal it is necessary to mutually harmonize all the elements relevant for the preferred production of container ser-

vices, such as means of transport, cargo and human resources. Thus, output values of one subsystem will represent the input parameters of the next subsystem. One of the difficulties that occurs in setting the optimal plan for transshipment and transportation of cargo is to collect the appropriate information. The mentioned data, at disposal in the process of designing the optimal plan, include capacity of the particular means of transport, transshipment costs per unit of cargo for each means of transport, freight costs per unit of cargo for each destination, expressed in monetary units and the demand of a particular destination.

A precise quantity of the cargo for the transshipment using different types of means of transport should be determined. Traffic and technological process in the port derives from the basic port activities, primarily cargo handling (direct or semi-direct) and warehousing. That is, it refers to the organization of transport of goods by inland means of transport to the ship and inversely. The basic elements of the transshipment problem are quantities of different types of cargo loaded/unloaded to/from the vessel, berths capacity and their throughput and different modes of cargo handling. The container exchange between the terminal and road or rail is a very complex and time-critical part of a port. Both container flows, inbound and outbound, are handled simultaneously. Thus, its effective operation determines terminal efficiency to a great extent [4].

In the process of resolving the transshipment problem, it is common to use forecasting methods to determine the amount of cargo that should be reloaded. In this case, those methods have not been used, knowing the exact total amount of the observed cargo. In this paper a vessel is selected as well as a certain number of containers transhipped during its stay at the observed port. Elements of the transshipment problem are presented with mathematical symbols (Table 1).

Table 1 – The notions and notations for used elements of transshipment

Type of cargo	$Q_i, i=1, \dots, m$
The amount of i -th type of cargo	q_i
Berth	$K_j, j=1, \dots, n$
The capacity of j -th berth	b_j
Mode of cargo handling	$M_k, k=1, \dots, l$
Transshipment costs of the i -th cargo in the j -th berth with the k -th handling mode	c_{ijk}
The quantity of i -th cargo on the j -th berth with the k -th mode of handling	x_{ijk}
Total transshipment costs	$\sum_{i=1}^m \sum_{j=1}^n \sum_{k=1}^l c_{ijk} \cdot x_{ijk}$
The transshipment capacities for trucks, rail and stacking area	d_v, d_r, d_s

The construction of port facilities is expensive and during the performance of the transshipment vessels occur with certain delays. This is manifested in a certain time mode of the port facilities caused either by irregular arrivals of the ships or by waiting for the cargo loading/unloading procedure to start [15]. High operating costs for ships and container terminals and also high capitalization of ships, containers and port equipment demand a reduction of unproductive times at ports [3].

The efficiency of the container terminal can be best determined by using the value indicators, in other words, with costs, since the waiting of the ship produces payments and the disengagement of the berths also carries a value [8]. The most favourable plan of cargo movement at a port refers to the decrease of cargo handling as each transfer makes its expenses. Avoiding unnecessary movements results in the reduction of labour costs and time. In addition, cargo damage is less likely. Both the route of yard-side equipment (such as transfer cranes or straddle carriers) and the number of containers picked up at each yard-bay is determined simultaneously [9].

If all the tasks in the working process operate synchronously, only then the overall service provided in the port is performed with high quality. In the case of alignment the regularity of vessel arrivals with the time required for loading/unloading of cargo, there would be no "conflict" between the ship owner and the port. This means that a certain number of vessels would come into the port according to precisely defined timetable for a specific day, using the means of transport in the predetermined order.

3. MODEL OF TRANSHIPMENT PROCESSES AT THE CONTAINER TERMINAL

Such models and the search for their solution lie in the complexity of mathematical calculations and finding of the optimum due to composite form of the objective function which contains several decision variables and constraints in a large solution space [16]. The plan for transshipment and transport of cargo is determined as a part of the plan of implementing port services, as it represents a solution for the cargo transshipment problem. The purpose of this plan is to properly deploy cargo quantities at disposal that will be transhipped at each berth and in the appropriate way within the observed time period. The containers must be stored in such a way, so that the amount of handling needed to place a container in the storage area and to remove it when required, is minimised. Therefore, it is important to minimise the total throughput time that is the handling time of loading all the containers onto the ships at berth [5].

In order to accomplish the main objective in this paper, the minimum of total transshipment costs are

taken as criteria. This plan can contribute to the effectiveness and compliance of traffic and technological process at the observed terminal. Each process of transshipment causes certain transshipment costs. Such costs are calculated per unit of cargo and expressed in monetary units. The procedure for computing mentioned costs encompasses: multiplication of time during unloading of a certain cargo unit, dispatching cargo into wagon or in the warehouse and the prices of port services for a certain cargo unit. For the computation of total unit costs, certain types of expenses from the total cost function, have been used.

These expenses contain:

- 1) total cost of ship-to-shore container cranes (STS) and bridge cranes, and
- 2) total cost of human resources.

The function of total costs is:

$$C = c_d + c_{td} \quad (1)$$

where:

C – the amount of total costs in the observed period of time, in currency units (€/h),

c_d – the amount of the costs per crane (€/h),

c_{td} – the amount of operation costs for the group of operators and drivers (€/h).

The total cost of ship-to-shore container cranes (STS) and bridge cranes given in (2) is [17]:

$$c_d = \left[D_o \cdot \frac{i(1+i)^{N_d}}{(1+i)^{N_d} - 1} + M_d \right] \cdot \frac{1}{365 \cdot 24} \quad (2)$$

where:

c_{d1} – the amount of the cost of Samsung container gantry crane (€/h),

c_{d2} – the amount of the cost of Post-Panamax container gantry crane (€/h),

c_{d3} – the amount of the cost of rubber tyred gantry crane (RTG) (transtainer) (€/h),

c_{d4} – the amount of the cost of rail-mounted stacking cranes (RMG) (€/h),

D_o – initial price of the crane (€),

N_d – economic duration of the crane (in years),

M_d – the cost of annual maintenance per crane (€)

i – interest rate.

The total cost of human resources is:

$$c_{td} = t_{td} \cdot g \quad (3)$$

where:

c_{td} – the amount of operation costs for the group of operators and drivers involved in the transshipment of 1 TEU (€/h),

t_{td} – the amount of the operation costs for one operator (€/h),

g – number of operators and drivers involved in the transshipment of 1 TEU.

The operation costs for one operator are:

$$t_{id} = \frac{x}{y \cdot z} \quad (4)$$

where:

- x – income per month (gross) (€),
- y – number of working days,
- z – number of working hours per shift (h).

The total unit costs are:

$$c_{ijk} = \frac{C_{ijk}}{n} \quad (5)$$

where:

- C_{ijk} – transshipment costs of the i -th cargo in the j -th berth with the k -th handling mode (€/TEU),
- C_{ijk} – the amount of total costs in the observed period of time, in currency units (€/h),
- n – number of transhipped containers per time unit (TEU/h).

The mathematical model for the cargo transshipment problem refers to the objective function:

$$\text{Min} Z = \sum_{i=1}^m \sum_{j=1}^n \sum_{k=1}^l c_{ijk} \cdot x_{ijk} \quad (6)$$

with constraints:

$$\sum_{j=1}^n \sum_{k=1}^l x_{ijk} = q_i, \quad i = 1, , m \quad (7)$$

$$\sum_{i=1}^m \sum_{k=1}^l x_{ijk} \leq b_j, \quad j = 1, , n \quad (8)$$

$$\sum_{i=1}^m \sum_{j=1}^n x_{ijk} \leq d_t, \quad k = 1, , l \quad (9)$$

$$\sum_{i=1}^m \sum_{j=1}^n x_{ijk} \leq d_r, \quad k = 1, , l \quad (10)$$

$$\sum_{i=1}^m \sum_{j=1}^n x_{ijk} \leq d_s, \quad k = 1, , l \quad (11)$$

$$\begin{aligned} x_{ijk} &\geq 0, \quad i = 1, , m \\ &\quad j = 1, , n \\ &\quad k = 1, , l \end{aligned} \quad (12)$$

The aim of the objective function (6) is to reach the minimum value due to the fact that c_{ijk} represents the amount of the cost. The first constraint (7) represents the amount of cargo to be unloaded, while the constraints numbered (8)-(11) are related to berth capacity and other transshipment capacities (trucks, stacking area, railways). The amount of cargo refers to a precisely defined number of containers that should be entirely unloaded from the observed vessel. The berth capacity of the two berths at disposal as well as other transshipment capacities are equal to the total amount of cargo. The capacities have been mutually aligned and also with the amount of cargo. Therefore, it is approved to introduce restrictions with “=” mark in the mathematical model.

4. PRACTICAL EXAMPLE OF THE CARGO HANDLING PROBLEM AT THE CONTAINER TERMINAL IN THE PORT OF RIJEKA

The process of planning the transshipment and transportation of cargo refers to berth planning on the container terminal in the port of Rijeka due to the current operation conditions and qualified human resources. In cooperation with the Adriatic Gate Container Terminal Inc., the collected data were obtained for testing the observed mathematical model.

Jadranska vrata d.d., company, fully-owned by Luka Rijeka d.d., had been the owner of the container terminal in the port of Rijeka until 2011. Thereafter the international port operator called International Container Terminal Services Inc. (ICTSI) has become a new strategic partner of the Jadranska vrata d.d. company, as the owner of 51% of shares and under a different name, now called Adriatic Gate Container Terminal. Container terminal in the port of Rijeka disposes with two berths on Kostrensko quay–South. Considering its geographical position, this shore is unprotected from the action of waves. Although the practice has shown that delays incurred due to bad weather conditions during transshipment are quite rare (several days in a year).

The length of the first berth (K_1) is 300 m and it accepts vessels that could be bound up to 30,000 dwt with a 12 m draft, while the sea depth along the coast amounts to 11.7 m. On this shore two Samsung ship-to-shore container cranes (STS) with equal technical and technological features are currently in exploitation. The theoretical capacity of the Samsung cranes is up to 30 TEU/h, while their actual capacity n_1 (exploitation, production) is 22 TEU/h. A new berth (K_2) has been constructed in the extension of the current one with the length of 328 m, while the sea depth along the coast amounts to 14.1 m. The two new ZPMC Post-Panamax ship-to-shore container cranes (STS) are placed on this upgraded shore. The exploitation characteristics of these cranes are applicable for handling of Post-Panamax container vessels with capacity from 8,000 to 10,000 TEU. The theoretical capacity of the ZPMC Post-Panamax cranes is up to 35 TEU/h, while their actual capacity n_2 (exploitation, production) is 26 TEU/h.

Depending on the requirements of the transshipment process, one of the Samsung cranes could proceed with operations on the new extended part of the shore thus enabling the transshipment of the vessel with three cranes. At the container terminal in the port of Rijeka there are three modes for cargo handling as follows [7, 8, 13, 15, 18]:

- 1) direct way where transshipment-containers are unloaded directly from the vessel to the truck.

- 2) semi-direct way where transshipment-containers are unloaded from the vessel to rail wagon, i.e. stacking area for reloading onto wagons,
- 3) indirect way where transshipment-containers are unloaded from the vessel to the stacking area.

Traffic and technological processes of transshipment at the container terminal in the port of Rijeka refer to the containers, all types of palletised cargo and so called “jumbo” bags. The selected terminal consists of 1,500 m² covered area for loading or unloading goods from a container, whether it is about direct way of transshipping (from the container into the truck and inversely) or about storage in 8,000 m² indoor storage. Irregularity of arrivals of vessels and land vehicles affects the efficiency of organization of technological processes at the container terminal. Hence, in practice indirect way of transshipment prevails, where containers are reloaded over the stacking area.

The total terminal area of a container terminal in the port of Rijeka amounts to 16.8 ha. The annual terminal capacity is 450,000 TEUs and the turnover of 600,000 TEUs is foreseen for 2015. The stacking area at the observed container terminal consists of two storage areas. The first one is for storing empty containers and special types of cargo (IMO, oversized cargo and BBK), while operations are performed using bridge cranes. The storage area amounts to 6.1 ha and the static capacity is 4,500 TEUs. The second one is storage full of containers and operations are performed using rubber tyred gantry cranes (RTG), with 5 ha of storage area and the static capacity of 4,600 TEUs [19].

The amount of the dynamic capacity of the static area of the terminal is based on the number of the means of transport at disposal as well as the accessible capacity required for dispatch. Dispatch of containers is defined by the ability of the terminal to perform a certain number of shipments per time unit. For the execution of transport and transshipment process at smaller container terminals, the most adequate way for handling is using the combination of different means of transport, as the case at a container terminal in the port of Rijeka. This combined system consists of four ship-to-shore container cranes (STS) for reloading operations at berths, six rubber tyred gantry cranes (RTG), two rail mounted stacking cranes (RMG),

six reach stackers, nine tractors, seventeen trailers and three forklifts.

4.1 Model testing

The transshipment problem [20] refers to two types of cargo (Q_1 and Q_2), which can be reloaded at two berths (K_1 and K_2) per shift (8h) with three different modes of cargo handling (M_1 , M_2 and M_3). The first type of cargo relates to the 40' containers (Q_1), while the other one refers to reloading of 20' containers (Q_2). The quantity of cargo amounts to 89 and 285, respectively. The first berth (K_1) can accept 46% and the second one (K_2) 54% of the total number of containers. Thus, the capacity of the berth is 172 and 202, respectively. The M_1 handling mode represents unloading of cargo from the vessel to the truck, M_2 denotes the process of unloading cargo from the vessel to the rail wagon and the M_3 handling mode is the process of unloading cargo from the vessel to the stacking area.

For all the above mentioned handling modes there are the following constraints:

- 90 containers are unloaded directly onto the trucks (constraint for M_1),
- 110 containers are deposited on the stacking area and then transhipped onto the wagons (constraint for M_2), and
- 174 TEUs are placed onto the stacking area (constraint for M_3).

If the type of cargo is characterized by $i=1,\dots,m$, the number of berths with $j=1,\dots,n$ and for handling modes $k=1,\dots,l$, then the 12 possible relations are obtained. Transshipment costs per unit (per TEU) are calculated according to formulas (1)-(5). One ship-to-shore container crane (STS) is in exploitation during the transshipment of one container per berth and accordingly the costs are calculated per crane in €/h.

Table 2 shows the data used for the computation of the costs for Samsung ship-to-shore container cranes (STS) and ZPMC Post-Panamax cranes, rubber tyred gantry cranes (RTG) as well as rail mounted stacking cranes (RMG). The results are computed according to Formula (2) and marked as c_{di} .

Furthermore, the overall cost of human resources have been calculated taking into consideration the technology of work during transshipment, where mechanization and port transport operators are actively involved. The process of transshipment of a vessel for

Table 2 - Input data and obtained costs results

Cranes	D_o	N_d	i	M_d	c_{di}
Samsung	7,000,000	10	5	700,000	183.39
Post-panamax	7,500,000	10	5	750,000	196.49
RTG	950,000	10	5	95,000	24.89
RMG	1,150,000	10	5	115,000	30.13
Unit	€	years	%	€	€/h

one TEU per shift requires seven employees, two of whom are crane operators, three tractor drivers and two bridge crane operators.

Table 3 shows the parameters for the computation of the cost of human resources that have been calculated for operation costs for one operator t_{id} according to Formula (4) and operation costs for the group of operators and drivers c_{id} according to Formula (3).

The calculated values in €/h have been obtained for the total cost of ship-to-shore container cranes (STS) and bridge cranes as well as total cost of human resources. For further calculations the function of total costs has been used for the final formation of unit costs value. The computation of the unit costs values is presented for the selected relations.

The calculations for the unit costs include the following information and data. For the calculation of values c_{111} , c_{112} and c_{113} by Formula (5) related to the first type of cargo (Q_1) and the first berth (K_1) the actual capacity of 22 TEU/h of Samsung cranes is taken into account. For the calculation of values c_{121} , c_{122} and c_{123} by Formula (5) related to the first type of cargo (Q_1) and the second berth (K_2) the actual capacity of 26 TEU/h of Post-Panamax cranes is taken into account. In the calculations of values c_{111} and c_{121} related to the first mode of cargo handling only the amount of the cost of Samsung cranes (c_{d1}) and Post-Panamax cranes (c_{d2}), respectively is taken into account. In the calculations of values c_{112} and c_{122} related to the second mode of cargo handling the sum of amounts of the cost of Samsung cranes and RTG crane ($c_{d1}+c_{d3}$) and the sum of amounts of Post-Panamax cranes and RTG crane ($c_{d2}+c_{d3}$), respectively are taken into account. In the calculations of values c_{113} and c_{123} related to the third mode of cargo handling the sum of amounts of the cost of Samsung cranes and RMG crane ($c_{d1}+c_{d4}$) and the sum of amounts of Post-Panamax cranes and RMG crane ($c_{d2}+c_{d4}$), respectively are taken into account.

Table 3 – The input data for the cost of human resources

Parameters	g	x	y	z	t_{id}	c_{id}
Value	7	1,056	22	8	6	42
Unit	-	€	days	h	€/h	€/h

Table 4 – Unit costs according to the type of cargo transshipment and handling mode (€/TEU)

Berth	K_1			K_2		
	M_1	M_2	M_3	M_1	M_2	M_3
Handling mode → Type of cargo ↓						
Q_1	10.24 x_{111}	11.38 x_{112}	11.61 x_{113}	9.17 x_{121}	10.13 x_{122}	10.33 x_{123}
Q_2	6.28 x_{211}	6.97 x_{212}	7.12 x_{213}	5.62 x_{221}	6.2 x_{222}	6.3 x_{223}

So, it follows that according to Formula (1) and taking into account the data of Samsung container gantry crane for the calculation of cd, the total cost for the $Q_1-K_1-M_1$ relation amounts to 225.39 €/h. For the same relation the unit cost is obtained by Formula (5), totalling 10.24 €/TEU. Analogously, for the $Q_1-K_1-M_2$ relation total cost amounts 250.28 €/h, while the unit cost is 11.38 €/TEU. For the $Q_1-K_1-M_3$ relation total costs amount to 255.52 €/h and the sum of total unit costs is 11.61 €/TEU.

For the calculation of unit costs for Q_2 type of cargo (20' containers), these costs were reduced by 38.6% compared to Q_1 type of cargo (40' containers), according to the data [19]. For example, c_{211} unit cost for $Q_2-K_1-M_1$ relation was obtained as $10.24/c_{ijk} = 62/38$ and amounts to 6.28 €/TEU. Thus, this calculation procedure has similarly been applied to computing the rest of cost values for transshipment unit cost for one TEU (c_{ijk}), for other relations, as stated in Table 4.

In this paper, ship-to-shore movement of cargo is implemented; both types of cargo can be unloaded on each of the two berths at disposal and appropriate different operation modes can be applied. The observed container vessel unloads a total of 374 containers at a container terminal in the port of Rijeka. Based on the received data, all x_{ijk} values are determined, i.e. the quantity of i -th cargo to be unloaded during the selected time period at the j -th berth, using the k -th handling mode, providing the lowest possible transshipment costs. The plan for transshipment and transportation of cargo has been developed by taking into consideration the same time unit (h).

Mathematical model for this practical problem is solved by applying the linear programming method:

$$MinZ=10.24x_{111}+11.38x_{112}+11.61x_{113}+9.17x_{121}+10.13x_{122}+10.33x_{123}+6.28x_{211}+6.97x_{212}+7.12x_{213}+5.62x_{221}+6.2x_{222}+6.3x_{223} \quad (13)$$

with constraints:

$$x_{111}+x_{112}+x_{113}+x_{121}+x_{122}+x_{123}=89 \tag{14}$$

$$x_{211}+x_{212}+x_{213}+x_{221}+x_{222}+x_{223}=285 \tag{15}$$

$$x_{111}+x_{112}+x_{113}+x_{211}+x_{212}+x_{213}=172 \tag{16}$$

$$x_{121}+x_{122}+x_{123}+x_{221}+x_{222}+x_{223}=202 \tag{17}$$

$$x_{111}+x_{211}+x_{121}+x_{221}=90 \tag{18}$$

$$x_{112}+x_{212}+x_{122}+x_{222}=110 \tag{19}$$

$$x_{113}+x_{213}+x_{123}+x_{223}=174 \tag{20}$$

$$x_{ijk} \geq 0, i=1,2; j=1,2; k=1,2,3 \tag{21}$$

The obtained optimal solution is the following:

$$\text{Min}Z=2739 \text{ €}$$

$$x_{121}=89 \text{ TEU}; x_{211}=1 \text{ TEU}; x_{212}=110 \text{ TEU}; x_{213}=61 \text{ TEU}; x_{223}=113 \text{ TEU}$$

The results of the considered model represent the basis for developing a plan of transshipment and transportation of containers that can be realized within the observed period of time. Therefore, this plan is ranked among the operational planning of the terminal. The deployment of the total quantity of containers at berths and different modes of container handling according to the costs criteria and exogenous constraints (capacity of trucks, wagons and stacking area) are presented graphically (Figure 1).

4.2 Results analysis

The optimal plan for the transshipment and transportation of cargo is shown in Table 5.

The first type of cargo (Q_1) will be entirely unloaded at the second berth (K_2), while the second cargo type

Table 5 – Plan for transshipment and transportation of cargo according to the mode of handling and type of cargo (TEU)

Type of cargo Handling mode	Q_1	Q_2	Total
M_1 (vessel-truck)	89	1	90
M_2 (vessel-rail)	-	110	110
M_3 (vessel-stacking area)	-	174	174
Total	89	285	374

(Q_2) will be transhipped at both berths (K_1 and K_2). The M_1 handling mode (ship-truck) will be applied for Q_1 and Q_2 types of cargo, M_2 (ship-rail, over stacking area for railway wagons) only for Q_2 type of cargo and M_3 (ship-stacking area) as well as for Q_2 type of cargo. The costs for the entire process of cargo handling amount to € 2,739. This is the minimum value of transshipment costs that enables transshipment of the total quantity of containers, taking into consideration unit transshipment costs. The analysis of constraints indicates that the capacity of trucks, wagons and stacking area are fully utilized and therefore there is no unused capacity. This might have been expected since the total cargo quantity for unloading equals the overall capacity of trucks, wagons and stacking area, and cargo can be unloaded using any of the handling modes at disposal [20].

$$\sum_{i=1}^m q_i = \sum_{j=1}^n b_j = \sum q_{others} \tag{22}$$

where:

q_{others} - other capacities for cargo handling, such as warehouses, rail and road vehicles, etc.

The regularity of ship arrivals and continuous time of loading/unloading have never been achieved in practice. Irregularity of vessel arrivals and unpredictable duration of unloading/loading operations suggest

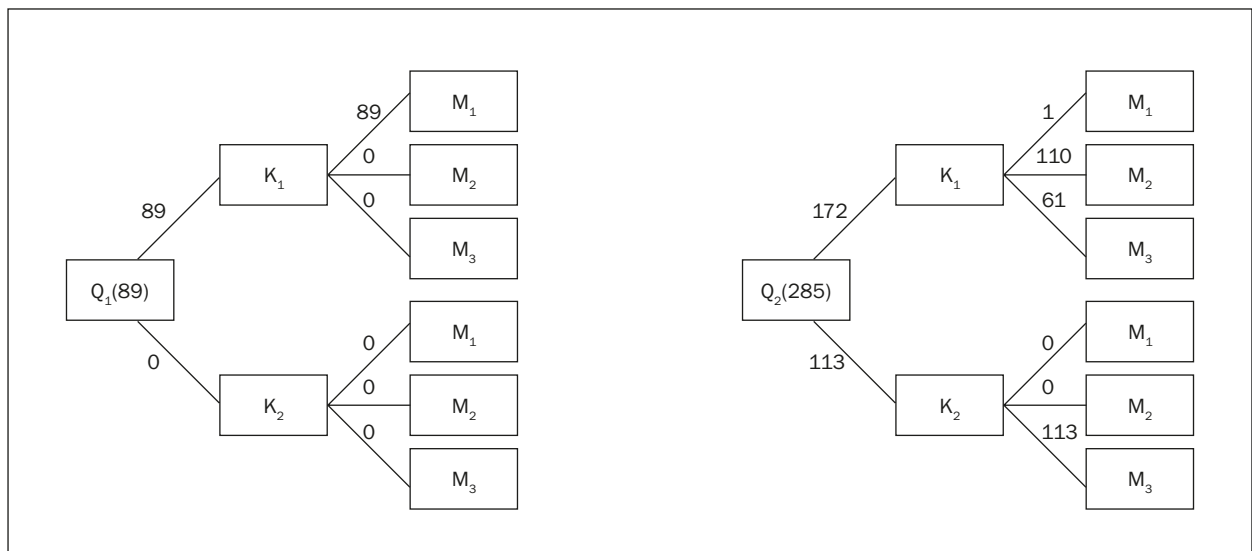

Figure 1 – Graphical presentation of the optimal solution

that in practice, the 100% of berth occupancy can be accomplished only under the condition of continuous and long waiting of vessels at anchorage, which creates high port expenses. Such cases are rare in practice. The port capacities for cargo handling are specific, inflexible and can hardly change rapidly according to the needs or demands. Cargo handling capacities include all the facilities for cargo handling (storage, port machinery, rail and road vehicles), which should be mutually harmonized, which is also difficult to obtain.

5. CONCLUSION

The increasing number of container shipments causes higher demands on the seaport container terminals, container logistics, and management, as well as on technical equipment. Successful operations and continuously researching possibilities for improvement are the primary purpose of modelling a certain port system. Operations are nowadays unthinkable without effective and efficient use of information technology as well as appropriate optimization (operations research) methods. Container terminals, as key points of transportation of containers, connect several traffic systems and can operate successfully only if activities of all the participants in transport have been harmonized. Congruently, the economic profitability of this type of transport can be provided.

The appropriate selection of adequate means of transport has a significant impact on the increase of container traffic as well as higher production effects. It is therefore of major importance to plan in advance traffic and technological process at the terminal. The optimal solution represents a plan for transshipment and transportation of cargo with the appropriate cargo handling mode being applied, within the observed time period, and taking into consideration minimum total transshipment costs. The optimization of the transshipment process has direct impact on the effectiveness of operations of the terminal, i.e. the possibility of preventing the congestion at terminals. The optimizing performance of the means at disposal can be achieved with effective planning and management as well as by making the appropriate business decisions.

The model of planning the transshipment process can be changed according to certain features of a particular problem. The model enables possible modifications (increase or decrease) of the number of types of cargo, berths and cargo handling, then quantities for each type of cargo, berth capacity, storages and other transshipment facilities. It also takes into consideration the special requirements for certain relations in the transport matrix as well as modification of the duration of the time period.

The derived model, being resolved by applying the linear programming method, has been tested on the

example at the container terminal in the port of Rijeka. The model can be implemented in daily operational planning of any container terminal and is applicable in a variety of operating conditions, which confirms the validity of the observed model set in the introduction of this paper.

MIA JURJEVIĆ, mag.ing.logist., doktorandica

E-mail: mijaJurjevic@gmail.com

Vozišće 12a, 51216 Viškovo, Hrvatska

Prof. dr. sc. **SVJETLANA HESS**

E-mail: shess@pfri.hr

Sveučilište u Rijeci, Pomorski fakultet u Rijeci

Studentska 2, 51000 Rijeka, Hrvatska

MODEL ZA OPERATIVNO PLANIRANJE PREKRCAJNIH PROCESA U LUCI

SAŽETAK

Modeliranje nekog prometnog sustava odnosi se na utvrđivanje uspješnosti poslovanja te ispitivanje mogućnosti za njegovo poboljšanje. Svaki kontejnerski terminal treba osigurati kontinuitet i dinamiku tijekom kontejnera. Cilj ovog rada je odrediti količinu pojedine vrste kontejnera koja će se, uz odgovarajuće rukovanje, prekravati na pojedinom pristanu uz minimalne ukupne troškove prekrcaja. U tu je svrhu postavljen matematički model planiranja prekrcaja i prijevoza kontejnera na terminalu. Optimalno rješenje, dobiveno metodom linearnog programiranja, predstavlja takav plan raspoređivanja kontejnera koji će osigurati učinkovit prekrcajni proces, uz osiguranje najmanjih troškova prekrcaja. Model je testiran na primjeru luke Rijeka i može biti temelj za donošenje odgovarajućih poslovnih odluka pri operativnom planiranju operacija na kontejnerskom terminalu.

KLJUČNE RIJEČI

operativno planiranje; prekrcajni procesi; optimalan plan prekrcaja kontejnera;

REFERENCES

- [1] Hess M, Kos S, Hess S. Queueing system in optimization function of port's bulk unloading terminal. *Promet – Traffic & Transportation*. 2007;19(2):61-70.
- [2] Hess M, Hess S, Kos S. On transportation system with deterministic service time. *Promet – Traffic & Transportation*. 2008;20(5):283-290.
- [3] Steenken D, Voß S, Stahlbock R. Container terminal operations and operations research – a classification and literature review. *OR Spectrum*. 2004;26(1):3-49.
- [4] Froyland G, Koch T, Megow N, Duane E, Wren H. Optimizing the landside operation of container terminal. *OR Spectrum*. 2008;30:53-75.
- [5] Kozan E, Preston P. Genetic algorithms to schedule container transfers at multimodal terminals. *International Transactions in Operational Research*. 1999;6:311-329.
- [6] Said G, El-Horbaty E. An Optimization Methodology for Container Handling Using Genetic Algorithm. *Procedia Computer Science*. 2015;65:662-671.

- [7] Gudelj A, Krčum M, Tvrđy E. Models and methods for operations in port container terminals. *Promet – Traffic & Transportation*. 2010;22(1):43-51.
- [8] Zenzerović Z, Vilke S, Jurjević M. Queueing theory in function of planning the capacity of container terminal in the port of Rijeka. [in Croatian]. *Pomorstvo*. 2011;25(1):45-69.
- [9] Kim KY, Kim KH. Heuristic algorithms for routing yard-side equipment for minimizing loading times in container terminals. *Naval Research Logistics*. 2003;50:498-514.
- [10] Won SH, Kim KH. An integrated framework for various operation plans in container terminals. *Polish Maritime Research*. 2009;16(3):51-61.
- [11] Kim KH, Lee H. Container Terminal Operation: Current Trends and Future Challenges. *Handbook of Ocean Container Transport Logistics (Chapter 2)*. Springer International Publishing Switzerland; 2015.
- [12] Cullinane K, Song D-W, Wang T. The application of mathematical programming approaches to estimating container port production efficiency. *Journal of Productivity Analysis*. 2005;24(1):73-92.
- [13] Zenzerović Z, Antonini N, Vilke S. Methodological approach to the service process research – container terminal at the port of Rijeka. [in Croatian]. *Pomorstvo*. 2012;26(1):227-250.
- [14] Gunther HO, Kim KH. Container terminals and terminal operations. *OR Spectrum*. 2006;28:437-445.
- [15] Oblak R, Hess S. Influence of the ship arrival process on the load of container yards at the container terminal. [in Croatian]. *Pomorstvo*. 2011;25(2):433-443.
- [16] Hess S, Hess M. Optimization of ship's operations by genetic algorithm. *Promet – Traffic & Transportation*. 2009;21(4):239-245.
- [17] Dundović Č, Zenzerović Z. An optimal capacity planning model for general cargo seaport. *Promet – Traffic & Transportation*. 2000;12(5-6):217-221.
- [18] Dundović Č, Hlača B. New concept of the container terminal in the port of Rijeka. *Pomorstvo*. 2007;21(2):51-68.
- [19] Adriatic Gate Container Terminal. [cited 2014 May 15] Available from: <http://www.ictsi.hr>
- [20] Zenzerović Z. Model of planning the transshipment processes in the seaport. [in Croatian]. *Zbornik radova Pomorskog fakulteta*. 1993;7(1):227-238.