

DENG PAN, Ph.D.  
E-mail: pandengreal@126.com  
YINGPING ZHENG, Prof.  
E-mail: zheng\_ying\_ping@hotmail.com  
Tongji University,  
School of Electronic & Information Engineering,  
Shanghai 201804, China

Traffic Engineering  
Preliminary Communication  
Submitted: Mar. 6, 2013  
Approved: July 8, 2014

## DYNAMIC CONTROL OF HIGH-SPEED TRAIN FOLLOWING OPERATION

### ABSTRACT

*Both safety and efficiency should be considered in high-speed train following control. The real-time calculation of dynamic safety following distance is used by the following train to understand the quality of its own following behaviour. A new velocity difference control law can help the following train to adjust its own behaviour from a safe and efficient steady-following state to another one if the actual following distance is greater than the safe following distance. Meanwhile, the stopping control law would work for collision avoidance when the actual following distance is less than the safe following distance. The simulation shows that the dynamic control of actual inter-train distance can be well accomplished by the behavioural adjustment of the following train, and verifies the effectiveness and feasibility of our presented methods for train following control.*

### KEY WORDS

*high-speed train; train following control; train behavioral adjustment; control strategy; automatic train control*

### 1. INTRODUCTION

High-speed train inevitably adjusts its own behaviour in the process of its own following operation according to the route conditions and the dynamic following situation between them, or the control commands of train operation. Because the braking distance of a train varies with its own speed, safe following distance will also change with the velocities of the following and preceding trains. High-speed train following control would undoubtedly help to improve the quality of train movement, make full use of transport potential of the railway line, and further raise the transportation efficiency.

Nowadays, more attention has been paid to the control of train following operation in the railway field, but the field of view is mainly limited to the fixed

block system and the semi-moving block system. In [1], the cellular automata were applied to the modelling, simulation of train following operation to find the laws of train following control. Reference [2] presented a calculation method of braking mode curve of high-speed train at a velocity of more than 250 km/h. Reference [3] proposed the emergency braking curves for train following operation of urban rail transit in worst cases, and discussed the ways to reduce the minimum train following distance under moving block system. Actually, in the process of train following operation, the separation distance between two trains always changes dynamically with their speeds. A constant safe distance cannot help train following system to move safely and efficiently. On the other hand, it is also unrealistic for the following train to abide unchangeably by a continuous one-step braking curve under a certain following speed in the complex and moving environment. The following train must assess the present situation and adjust its own behaviour according to the assessment results in order that the dynamic control of actual following distance can promote the safer and more efficient train operation. In contrast, the highway traffic field has a longer study history on vehicle following control, during which many models, such as the General Motors model [4], the model of safe following distance [5, 6] and the optimal velocity model [7], appear one after another. Jiang et al. [8] first built the full velocity difference model to overcome the shortage of the generalized force model [9] in describing the time delay, the phase transition of traffic flow and the evolution of traffic congestion. Reference [10] presented a model of car following based on full velocity difference and full acceleration difference and obtained good simulation results. In [11] the correlation coefficient was introduced into the optimal velocity difference model for its optimization, but yet no practical

and effective solution to determine the correlation coefficients dynamically. Gong et al. [12] proposed an asymmetric full velocity difference car-following model to reduce the safety risks in the generalized force model and the full velocity difference model, which would probably lead to a situation in which the following vehicle would not slow down even if the distance between the leading and the following vehicles is extremely short. Desjardins and Chaib-draa [13] studied a desired trajectory through the state space {the headway, the headway derivative, the front-vehicle acceleration} realized by the time-sequence of the behavioural adjustment strategies from the action space {a braking action, a gas action, a “no-op” action}. The safe following distance (called “safe inter-distance” in [14]) can be used to evaluate and improve the quality of vehicular behaviour. Somda and Cormerais [14] attached importance to the dynamic calculation of safe following distance in their study of vehicular auto-adaptive intelligent cruise control system, where the relative braking mode was used to calculate the safe inter-distance. Unfortunately, there is lack of clarity on the dynamic calibration of safe inter-distance under the relative braking mode when the preceding vehicle is speeding up. Moon et al. [15] studied the design, tuning and evaluation methods of a full-range adaptive cruise control system with collision avoidance; a necessary measure can be provided to evaluate the implementation of “safety first” principle. Moreover, the term “full-range” presented in [15] may be able to give a direction to the future study of vehicle following control and vehicular adaptive cruise control.

The efficiency is another optimization objective of vehicle following control besides safety. In some literature, the “efficiency” was defined as the level of energy consumption [16, 17]. Here, the “efficiency” is defined as the utilization level of the line transport capacity by vehicle following system, that is to say, the actual following distance should be a little longer than the dynamic safety following distance at any time in the process of vehicle following operation.

The above mentioned research results provide much more consideration to train following control. However, the elaborations were not given for the following vehicle to realize the real-time tracking of dynamic safety following distance. On the other hand, there is not a widespread concern over high-speed train following control of future railway moving block system. In general, high-speed train moves at a speed greater than 250 km/h, even up to 380 km/h. Focusing on the “moving” and “changing length” features of train following distance in railway moving block system, some explorations and attempts are made in the real-time calibration of dynamic safe following distance within the full-range velocities and the dynamic control of train following distance for safety and efficiency.

## 2. SAFE FOLLOWING DISTANCE AND ITS CALCULATION

### 2.1 Definition of safe following distance

Safe following distance is one of the important basic data for the scientific behavioural adjustments of high-speed train. In order to make full use of the line transport capacity, here, “safe following distance” under different following velocity is defined as the standard values, which should be a minimum following distance kept by the following train from the preceding train, and can help the following train to travel safely, efficiently and smoothly (comfort).

### 2.2 Calculation of safe following distance

The safe following distance can be calculated under the absolute or relative braking mode. Under the absolute braking mode, the following train can use its own current position and velocity, as well as the current tail position of the preceding train to calculate the target-distance braking curve at the normal or worst case for its own behavioural adjustments. In turn, the target-distance braking curve can also be used to calculate and determine the dynamic safety following distance for the following train to move safely and efficiently. In the relative braking mode, not only the tail position of the preceding train but also its behavioural adjusting strategy are regarded as important data for the determination of the target-distance braking curve and the calculation of dynamic safety following distance. We can see that under the same following velocity, the safe following distance of the relative braking mode is shorter than that of the absolute braking mode, and as result, more efficient than the latter. However, in the view of the complexity of the relative braking mode applied to train following control, our discussions about the calculation of safe following distance and train following control will be confined only to the absolute braking mode.

According to the achievements of Zimmermann and Hommel [18] in train control system, the calculation of train following distance can be seen in *Figure 1*, where  $S_{Safe}$  is safe following distance between the leader and the follower.

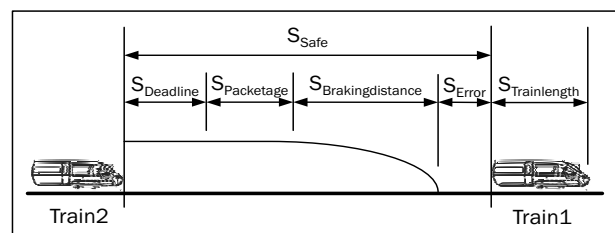

Figure 1 - Train following distance

$S_{Safe}$  can be expressed as follows [18]:

$$S_{Safe} = S_{Deadline} + S_{Package} + S_{Brakingdistance} + S_{Error} \quad (1)$$

where  $S_{Deadline}$  is the distance travelled by the following train within the time deadlines of its registering to RBC,  $S_{Package}$  is the distance travelled by the following train within the converted communication time,  $S_{Brakingdistance}$  is train braking distance.  $S_{Error}$ , the error of spatial interval calculation and control, is taken as 50 metres. Additionally,  $S_{Trainlength}$  is the train length with a typical value of 410 metres [18].

For a train, the greater its following velocity is, the farther its braking distance will be. But the increase of safety often implies that the line transport capacity cannot be utilized very well. Therefore, the actual following distance  $S$  must be equal to or slightly greater than  $S_{Safe}$  at any time in the process of train following operation. Only in this way can the safety and efficiency of the train following operation be ensured and the spatiotemporal margins for the recovery of the normal train organization from the disorder provided.

### 3. DYNAMIC CONTROL OF TRAIN FOLLOWING DISTANCE

#### 3.1 Dynamic calibration of safe following distance

Due to the demands of train following control for safety and efficiency, the train following distance under any following situations has its own optimal value. Based on [18-21], the fitting function of  $S_{Safe}$  changing with the velocity  $V_2$  of Train2 can be obtained as in (2).

$$S_{Safe} = 0.81 \times V_2^2 + 48.72 \times V_2 + 281.60 \quad (2)$$

Clearly,  $S_{Safe}$  increased with the rising of Train2 velocity. It can be used by Train2 to calculate the dynamic safe following distance in real time under the absolute braking mode. According to the principle of "safety first", at any time and any speed, the behavioural adjustments of Train2 must be binding subject to the fulfilment of the following conditions.

$$S \geq S_{Safe} \quad (3)$$

At the same time, the train following system would move in poor efficiency if the value of  $S - S_{Safe}$  was too high. Therefore, sometimes the dynamic safe following distance implies track resistances and sometimes it implies track attractions for the reasonable adjustment of the following train's behaviour.

#### 3.2 Control model of train following operation

The diagram of high-speed train operation control can be seen in *Figure 2*, where  $a_1$  and  $a_2$  are the accel-

erations of Train1 and Train2, respectively;  $V_{10}$  and  $V_{20}$  are the initial velocities of Train1 and Train2, respectively;  $V_1$  and  $V_2$  are the present velocities of Train1 and Train2, respectively;  $S_{10}$  and  $S_{20}$  are the initial positions of Train1 and Train2, respectively;  $S_1$  and  $S_2$  are the present positions of Train1 and Train2, respectively.

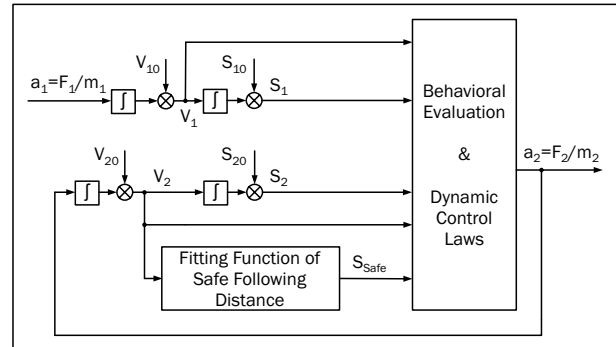

Figure 2 - Control of high-speed train following operation.

As shown in *Figure 2*, the behavioural adjustment of Train1 or Train2 must be realized respectively by its own acceleration, i.e. train unit resultant force. Besides the dynamic information of route conditions and the control command from railway station or train control centre, Train2 must regard the operation states of Train1 and Train2, the current following distance and the current safety following distance between them as the important source data to calculate and determine its own next step behaviour scientifically.

#### 3.3 Control strategy of train following operation

Here, a safe and efficient steady-following state is regarded as the initial state of the train following system. Train2 should adapt its own behavioural adjustment to the behavioural change of Train1.

When Train1 speeds up,  $S > S_{Safe}$  will become true and means the line transport capacity cannot be fully utilized by the current state of train following operation. Train2 should speed up to reduce the distance from Train1 until a new safe and efficient steady-following state is re-established.

When Train1 slows down or stops in emergency, the actual following distance would be less than the safe following distance if Train2 continues travelling at the constant velocity, i.e.  $S < S_{Safe}$ . In order to eliminate the risk of collision, Train2 should slow down or stop immediately, and the current actual distance  $S$  between two trains can be viewed as its stopping distance.

Certainly, Train2 would not change its behaviour if Train1 kept its constant velocity forward. So the old safe and efficient steady-following state with  $S = S_{Safe}$  will be maintained until it is broken.

### 3.4 Control laws of train behavioural adjustment

#### 1) Control law 1

The safe and efficient steady-following state is broken by the behavioural adjustment of the preceding train. If  $S > S_{Safe}$ , Train2, the following train, will adjust its own behaviour to reach a new safe and efficient steady-following state. The control law of train behavioural adjustment will help Train2 to travel safely and efficiently.

By (2), we get

$$\frac{d}{dt} S_{Safe} = \frac{d}{dV_2} S_{Safe} \times \frac{d}{dt} V_2. \quad (4)$$

By the safety consideration to train following operation, we can get

$$S_1 - S_2 - S_{Train\ length} \geq S_{Safe}. \quad (5)$$

By (4) and (5), we can get the control law of Train2 behavioural adjustment in  $dt$  time.

$$|a_2| \leq \left| \frac{V_1 - V_2}{\frac{d}{dV_2} S_{Safe}} \right|. \quad (6)$$

Considering the utilization level of line transport capacity, we take

$$a_2 = \frac{V_1 - V_2}{\frac{d}{dV_2} S_{Safe}}, \quad (7)$$

In comparison with [8] and [9], the new velocity difference equation (see (7)) can track dynamic safety following distance better. Thus, the control law can be expressed as follows:

$$\begin{cases} a_2 = \frac{V_1 - V_2}{1.62 \times V_2 + 48.72} \\ t = 1.62 \times V_2 + 48.72 \end{cases} \quad (8)$$

where the current speed  $V_2$  of Train2 is viewed as the initial velocity of Train2 behavioural adjustment, the current velocity  $V_1$  of Train1 as the final velocity of Train2 behavioural adjustment, and  $t$  is the maximum time of Train2 behavioural adjustment.

For the convenience of dynamic calculation and computer control, Equation (8) is written in a discrete form as follows:

$$\begin{cases} a_2(k) = \frac{V_1(k) - V_2(k)}{1.62 \times V_2(k) + 48.72} \\ t(k) = 1.62 \times V_2(k) + 48.72 \end{cases} \quad (9)$$

where  $k$  denotes the  $k^{th}$  sampling period.

It is clear that the sampling period is far less than parameter  $t(k)$  in (9). Here, parameter  $t(k)$  is just regarded as a theoretical constraint for every behavioural adjustment of the following train.

From (9), we can assert that the new velocity difference control equation can enable train following system enter into a (new) steady-following distance, which would be a safe steady-following state if the initial state of the train following system is safe. On the other

hand, Equation (9) is built on the basis of the fitting function of dynamic safety following distance changing with the velocity of the following train. Therefore, the following train can adjust its own behaviour according to (9) for the establishment of a new safe and efficient steady-following state from an old one. Based on the rational principle of human being, a reasonable initial state is necessary for anyone of the train following control system.

#### 2) Control law 2

If Train1 does not change its own behaviour, the safe and efficient steady-following state should be maintained to ensure the train following system to move in safety and efficiency. In this case, Train2 does not exert any control to adjust its own behaviour.

#### 3) Control law 3

When the safe and efficient steady-following state is broken by the deceleration of Train1 and  $S < S_{Safe}$ , collision would occur if Train2 does not take a corresponding measure of slowing down in time. Theoretically, the control law of Train2 behavioural adjustments can be also calculated according to (9), but due to the behavioural adjustment of Train2 lagging behind that of Train1, if the decreasing trend of the train following distance spreads continuously, especially when  $S < S_{Safe}$ , the crash risk of train following operation will increase largely. Here, according to the principle of "safety first", the actual following distance between trains must be controlled efficiently to avoid the collision.

According to Newton Kinematic Theorem, we can get the corresponding control law:

$$\begin{cases} a_2 = \frac{-V_2^2}{2 \times S} \\ t = \frac{2 \times S}{V_2} \end{cases} \quad (10)$$

where  $t$  is the maximum time of Train2 behavioural adjustment.

Equation (10) can be also written in a discrete form below:

$$\begin{cases} a_2(k) = \frac{-V_2^2(k)}{2 \times S(k)} \\ t(k) = \frac{2 \times S(k)}{V_2(k)} \end{cases} \quad (11)$$

The following train can take the control law shown in (11) to adapt the behavioural change of the preceding train during every sampling period. On the other hand, the fact of the sampling period far less than  $t(k)$  would ensure the safety of train following control in real time. In practice, according to the "safety first" principle, we do not have to calculate the control law in every sampling time.

In general, data acquisition and computing are very fast. Train2 follows the "safety-first" principle to slow



down and stop, while its behavioural adjustment is far from over; the evaluation of the train following behaviour and the calculation of control law for the next step behavioural adjustment of Train2 have begun or have already been implemented. Thus, the behavioural adjustment of Train2 can keep in step with the dynamic evolution of the train following situation, reflecting the characteristics of the real-time and dynamic control for its own safe and efficient following operation.

#### 4. SIMULATION AND ANALYSIS

Suppose that Train2 travels in pace with Train1 at a uniform speed of 300 km/h and a constant distance of 10,965.40 meters; Train1 first speeds up at an acceleration of  $0.2 \text{ m/s}^2$ ; when the speed of Train1 reaches 350 km/h, Train1 will maintain this constant speed to travel for 60 seconds; then, Train1 slows down and stops with a constant acceleration of  $-0.8 \text{ m/s}^2$ . The description of Train1 behaviour is shown in Figure 3.

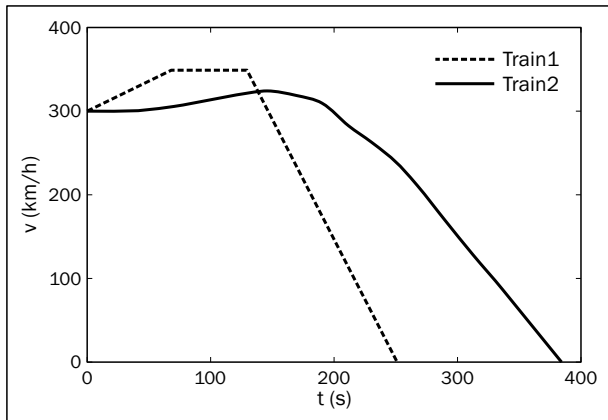

Figure 3 - V-t curve of Train1 and Train2

Figure 4 reflects the calculation of the control law of Train2 behavioural adjustments. The behavioural adjustments of Train2 corresponding to that of Train1 can be seen in Figures 3, 5 and 6.

As seen in Figure 5 and Figure 6, Train2 can adjust its own behaviour according to its own current speed

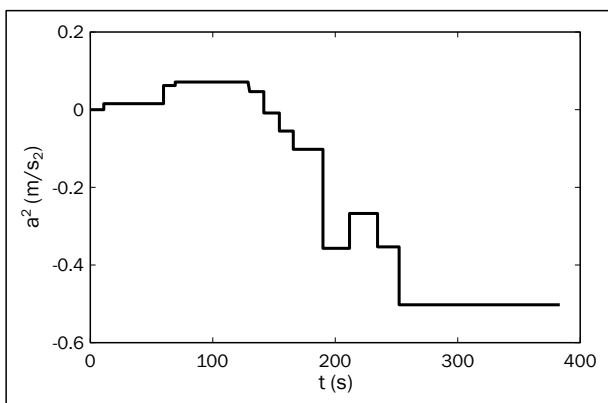

Figure 4 - Control laws of Train2

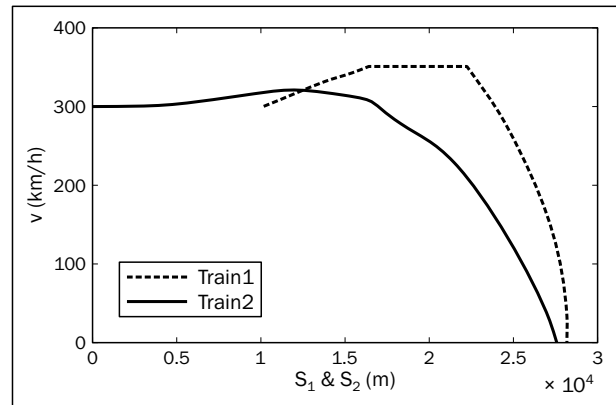

Figure 5 - Velocity-distance curves of Train1 and Train2

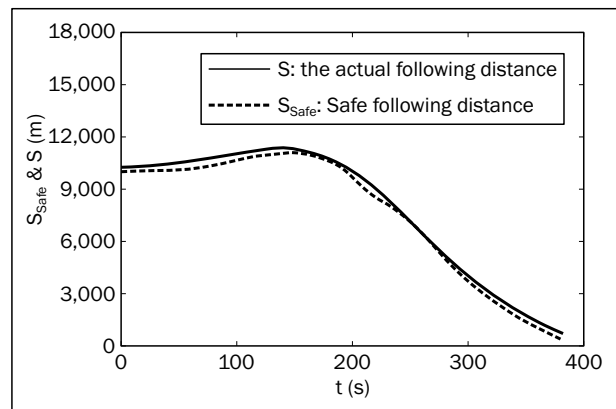

Figure 6 - Safety of train following operation

and the current safety following distance to make the actual following distance between two trains be adjusted dynamically and rationally. As result, safe and efficient train following operation can be achieved by our control method based on the dynamic calibration of the safe following distance.

In Europe, Japan and China, advanced train control systems take the “distance-to-go” technology [22, 23], which does not involve the real-time calibration of dynamic safety following distance at any following velocity from 0 km/h to 500 km/h in the complex transport environment.

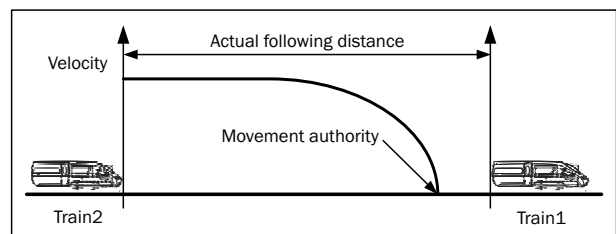

Figure 7 - The “distance-to-go” curve

As shown in Figure 7, the following train moves according to the “distance to go” curve under the premise of it travelling at a regulation maximum velocity permitted by the railway line. Obviously, the “distance-to-go” technology can undoubtedly ensure the safety of

train following operation. However, how to ensure that the following train moves in safety and efficiency under the complex following situation? Clearly, the pure "distance-to go" technology would not be up to the task. For example, it cannot improve the train following efficiency when the safe and efficient steady-following state is broken by the speeding up of the preceding train. Comparatively speaking, in the presented methods the real-time safe following distance can be used to evaluate the quality of train following operation, and then the following train can adjust its own behaviour scientifically according to the evaluation results to move in safety and efficiency.

In addition, most study results currently focus on the vehicle following control with the following velocity being less than 120 km/h. The simulation shows that our presented method is suitable to the vehicle following control under the condition of higher following velocity.

## 5. CONCLUSION

The braking distance of a train is closely related to the performance, the current velocity and the braking strategy of its own. High-speed train should abide by the standards of the braking distance and the following distance under different following velocities. In the CBTC-Based (Communication-Based Train Control) moving block system, the information such as the performance parameters, the operation status, the positions and the control strategies of the preceding and the following trains, etc. can be transmitted between each other by wireless communication. Therefore, the construction of a train control strategy library will help to enrich the control techniques and raise the level of train following control, and further improve the quality of train following operation in the complex railway transportation environment. If the industry authority and the related academic society could give the standards of the braking distance of high-speed train with different decelerating strategy under different following velocity, (not just the braking distance in emergency), it would not only create a better condition for academics to study high-speed train following control more comprehensively and more thoroughly, but also help to regulate and lead the development of locomotive and train industry.

## ACKNOWLEDGMENT

This work is supported by the National Nature Science Foundation of China (Grant No. 61174183).

潘登, 郑应平  
同济大学电子与信息工程学院, 上海 201804

摘要

高速列车跟驰运行的动态控制

安全和效率是高速列车跟驰控制过程中应当考虑的两个方面。后车可以通过动态安全车距的实时标定来了解自身的跟驰行为质量。如果实际车距大于安全车距, 后车可以借助于一个新的速差公式进行自身行为的调整, 以从一个安全高效跟驰稳态进入到另一个安全高效跟驰稳态; 而当实际车距小于安全车距时, 停车控制律将发生作用以避免列车冲突。仿真表明, 列车间隔可以通过后车的行为调整得到良好的控制, 所提列车跟驰控制方法具有一定的有效性和可行性。

关键词

高速列车; 列车跟驰控制; 列车行为调整; 控制策略; 列车自动控制

## REFERENCES

- [1] Fu YP, Gao ZY, Li KP. *Modeling Study for Tracking Operation of Subway Trains Based on Cellular Automata*. Journal of Transportation Systems Engineering and Information Technology. 2008;8(4):89-95.
- [2] Shang GW, Cai BG, Wang JJ. *Braking mode curve arithmetic of high-speed train above 250 km-h-1*. Journal of Traffic and Transportation Engineering. 2011;11(3)41-46, 54.
- [3] Lu F, Song MM, Li XL. *Research on Subway Train Following Control System under Moving Block System*. Journal of System Simulation. 2005;17(8):1944-1950.
- [4] Chandler RE, Herman R, Montroll EW. *Traffic Dynamics: Studies in Car Following*. Operations Research. 1958;6(2):165-184.
- [5] Kometani E, Sasaki T. *Dynamic behavior of Traffic with a Nonlinear Spacing-speed Relationship*. Proceedings of the Symposium on the Theory of Traffic Flow. New York: Elsevier; 1959. p.105-119.
- [6] Gipps PG. *A Behavioral Car-following Model for Computer Simulation*. Transportation Research Part B. 1981;15(2):105-111.
- [7] Bando M, Hasebe K. *Dynamic model of traffic congestion and numerical simulation*. Physical Review E. 1995;51(2):1035-1042.
- [8] Jiang R, Wu QS, Zhu ZJ. *Full velocity difference model for a car-following theory*. Physical Review E. 2001;64(7):017101-1-017101-4.
- [9] Helbing D, Tilch B. *Generalized force model of traffic dynamics*. Physical Review E. 1998;58(1):133-138.
- [10] Zhao X, Gao Z. *A new car-following model: full velocity and acceleration difference model*. European Physical Journal B. 2005;47(1):145-150.
- [11] Peng GH, Cai XH, Liu CQ. *Optimal velocity difference model for a car-following theory*. Physics Letter A. 2011;375(45):3973-3977.
- [12] Gong HX, Liu HC, Wang BH. *An asymmetric full velocity difference car-following model*. Physica A -Statistical Mechanics and Its Applications. 2008;387(11):2595-2602.

- [13] **Desjardins C, Chaib-draa B.** *Cooperative Adaptive Cruise Control: A Reinforcement Learning Approach.* IEEE Transactions on intelligent transportation systems. 2011;12(4):1248-1260.
- [14] **Somda FH, Cormerais H.** *Auto-adaptive and string stable strategy for intelligent cruise control.* IET Intelligent Transport Systems. 2011;5(3):168-174.
- [15] **Moon S, Moon I, Yi K.** *Design, tuning and evaluation of a full-range adaptive cruise control system with collision avoidance.* Control Engineering Practice. 2009;17(4):442-455.
- [16] **Khayyam H, Nahavandi S, Davis S.** *Adaptive cruise control look-ahead system for energy management of vehicles.* Expert Systems with Applications. 2012;39(3):3874-3885.
- [17] **Ke B-R, Lin C-L, Yang C-C.** *Optimisation of train energy-efficient operation for mass rapid transit systems.* IET Intelligent Transport Systems. 2012;6(1):58-66.
- [18] **Zimmermann A, Hommel G.** *Towards modeling and evaluation of ETCS real-time communication and operation.* Journal of Systems and Software. 2005;77(1):47-54.
- [19] **Huang WY, Yang NQ, Huang M.** *Standard of Railway Train Emergency Braking Distance Limit in China.* China Railway Science. 2003;24(5):84-90.
- [20] **Huang WY, Zhang ZY.** *Speed Limits of Railway Train Braking.* China Railway Science. 2007;28(6):91-95.
- [21] *Railway technical management regulations.* No. 29 command of China's Railway Ministry; 2006.
- [22] **Morar S.** *Evolution of communication based train control worldwide.* Proceedings of the 11<sup>th</sup> IET Professional Development Course on Railway Signalling and Control Systems. London, UK, May 2012; p. 218-226.
- [23] **Rumsey AF.** *Developments in train control worldwide.* 11<sup>th</sup> IET Professional Development Course on Railway Signaling and Control Systems. York, UK: IET, June 2006; p. 223-232.

